

Ellister van der Molen  
[info@ellister.com](mailto:info@ellister.com)  
cell: +31655338177



Bob Wijnen  
[info@bobwijnen.com](mailto:info@bobwijnen.com)  
Cell: +31624288062

## Rider Triplicate

### Technical:

**Stage dimensions:** at least 5x4 square meters.

**Instruments:** a tuned grand piano with bench or stool that is adjustable in height

**Trumpet:** brings own DPA 4099 clip/on mic (phantom power required); please supply a wireless mic with boom stand for the announcements

**piano:** please supply a tuned grand piano with an adjustable stool and 2 x mic Neumann KM84 or comparable on boom stand

**bass:** please supply a good bass amp, preferably Acoustic Image top and speaker but at least the sound quality of Gallien Krueger Microbass amps. Mic: Neumann U87 or comparable, placed 30-45cm from the bridge on a boom stand.

Two **monitors** at least the sound quality of Mackie SRM350 speakers.

**Power outlet:** 3 \* AC 220V earthed (European standard)

**Stage lights** don't have to be enormous, but three spotlights on the performing artists will do plus various spots at the back of the stage in different colours. Our show is mainly about the music so lighting should be more supportive than spectacular.

### Hospitality:

**On stage:** two bottles of refrigerated mineral water per performing artist.

**Backstage:** two lockable private rooms with mirror, chairs, towels and lights as well as a reasonable supply of soft drinks (six bottles at least) and assorted fruits and little snacks.

**Questions? Problems?** Don't panic, just call!

Monitor

2x220V

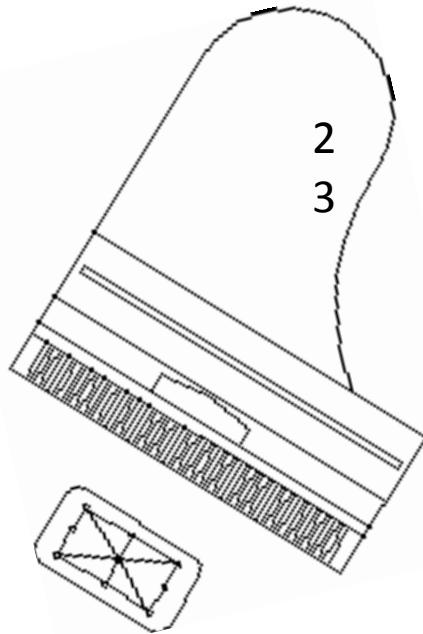

Bass  
Amp

Acoustic  
Bass

4

Trumpet

1

Monitor

2x220V

FOH  
speaker

- Input list:
- 1 - Trumpet mic (AKG C414 or comparable)
  - 2 and 3 – Piano mics (Neumann KM84 or comparable)
  - 4 - Acoustic bass mic (Neumann U87 or comparable)

FOH  
speaker